

1/4" HEX. SUPER DUTY SCREWDRIVER

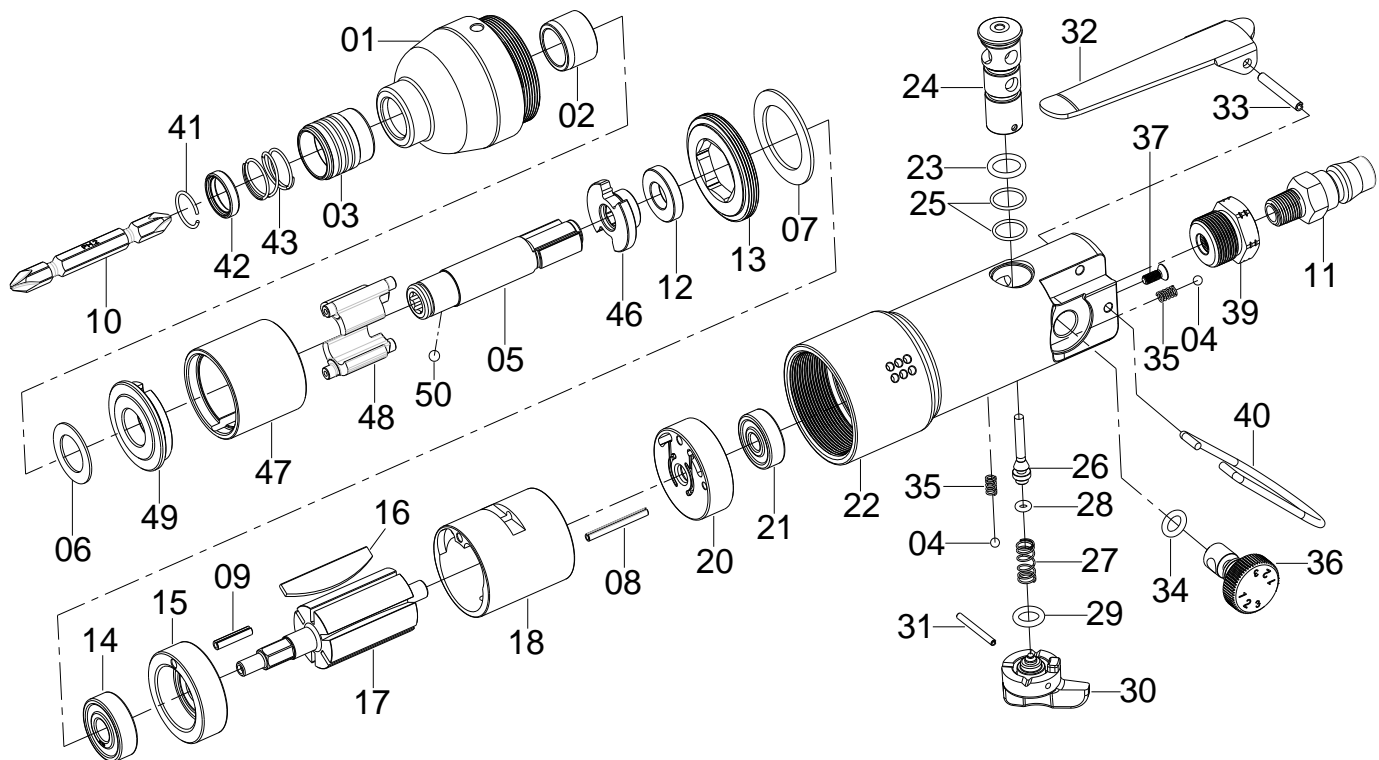

3238 3238A

INDEX NO.	DESCRIPTION	REQ'D NO.	INDEX NO.	DESCRIPTION	REQ'D NO.
★ 01	Hammer Case Assembly (incl.02)	1	26	Valve Stem	1
● 02	Bushing	1	27	Throttle Valve Spring	1
03	Release Sleeve	1	28	O-Ring	1
04	Steel Ball	2	29	O-Ring	1
05	Standard Anvil	1	30	Reverse Knob	1
06	Washer	1	31	Spring Pin	1
07	Washer	1	32	Trigger	1
08	Spring Pin	1	33	Spring Pin	1
09	Spring Pin	1	34	O-Ring	1
10	Bit	1	35	Steel Ball Spring	2
11	Quick Connect Plug	1	36	Air Regulator	1
12	Washer	1	37	Screw	1
13	Coupling Nut	1	39	Air Inlet	1
● 14	Ball Bearing	1	40	Hanger	1
★ 15	Front End Plate Assembly (incl.14)	1	41	Socket Retainer	1
16	Rotor Blade	6	42	Washer	1
17	Rotor	1	43	Spring	1
18	Cylinder	1	46	Hammer Cam	1
★ 20	Rear End Plate Assembly (incl.21)	1	47	Hammer Frame	1
● 21	Ball Bearing	1	48	Hammer	2
22	Motor Housing	1	49	Front Cover	1
23	O-Ring	1	50	Steel Ball	1
24	Value Bushing	1			
25	O-Ring	2	TK	Tune-Up Kit { incl.4.16 (6).23.25.27.28.29.34.35.43 }	

★ Must be Purchased in Assembly Set

● Recommended not to be purchased alone due to assembly difficulty

20150810R1