

3/4" SQ. DR. SUPER DUTY IMPACT WRENCH

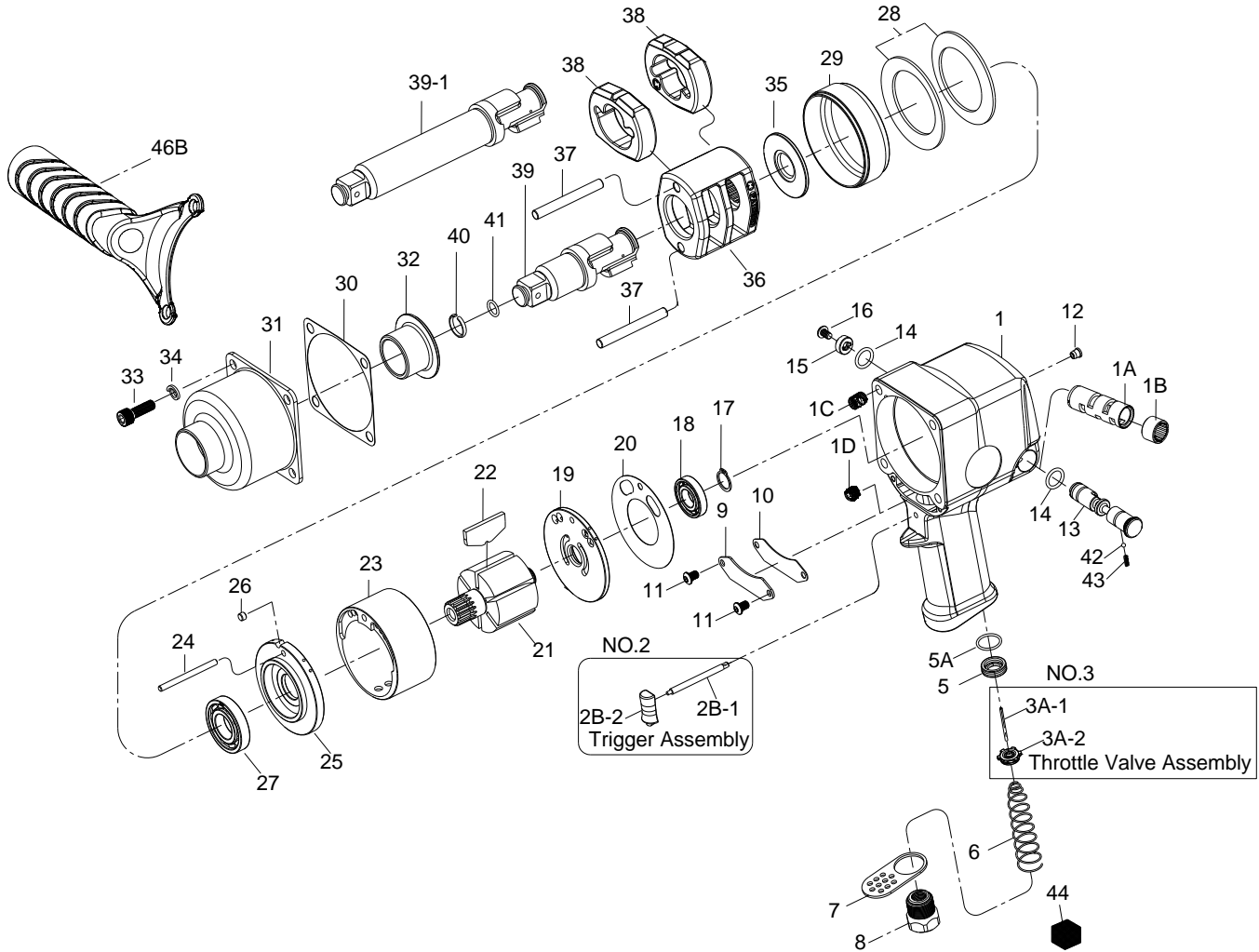

30_30-6

INDEX NO.	DESCRIPTION	REQ'D NO.	INDEX NO.	DESCRIPTION	REQ'D NO.
★ 1	Housing Assembly { incl.1A.1B.1C (4).1D.12 }	1	21	Rotor	1
● 1A	Reverse Valve Bushing	1	22	Rotor Blade	6
● 1B	Reverse Valve Bushing Gear	1	23	Cylinder	1
● 1C	Heli-Coil	4	24	Cylinder Dowel	1
● 1D	Set Screw	1	★ 25	Front End Plate Assembly (incl.27)	1
★ 2	Trigger Assembly (incl.2B-1.2B-2)	1	26	Pin	1
● 2B-1	Trigger Pin	1	● 27	Ball Bearing	1
● 2B-2	Trigger	1	28	Motor Clamp Washer	2
★ 3	Throttle Valve Assembly (incl.3A-1.3A-2)	1	29	Separator	1
● 3A-1	Throttle Valve Pin	1	30	Gasket	1
● 3A-2	Throttle Valve	1	31	Hammer Case	1
5	Throttle Valve Seat	1	32	Bushing	1
5A	O-Ring	1	33	Screw	4
6	Spring	1	34	Spring Washer	4
7	Exhaust Deflector	1	35	Washer	1
8	Air Inlet	1	36	Hammer Frame	1
9	Housing Plate	1	37	Hammer Pin	2
10	Gasket	1	38	Hammer	2
11	Screw	2	39	Standard Anvil (for KI-30)	1
● 12	Grease Fitting	1	39-1	6" Extended Anvil (for KI-30-6)	1
13	Reverse Valve	1	40	Socket Retainer	1
14	O-Ring	2	41	O-Ring	1
15	Reverse Valve Knob	1	42	Steel Ball	1
16	Screw	1	43	Spring	1
17	Retainer	1	44	Muffler Element	1
● 18	Ball Bearing	1	46B	Handle (Option)	1
★ 19	Rear End Plate Assembly (incl.18)	1	TK	Tune-Up Kit { incl.5A.6.14 (2).20.22 (6).30.40.41.42.43. }	
20	Gasket	1			

★ Must be Purchased in Assembly Set

● Recommended not to be purchased alone due to assembly difficulty

20130522R2